

HDM

DC MOTOR STANDARD TYPE

4H11D SERIES

750W



DIMENSION

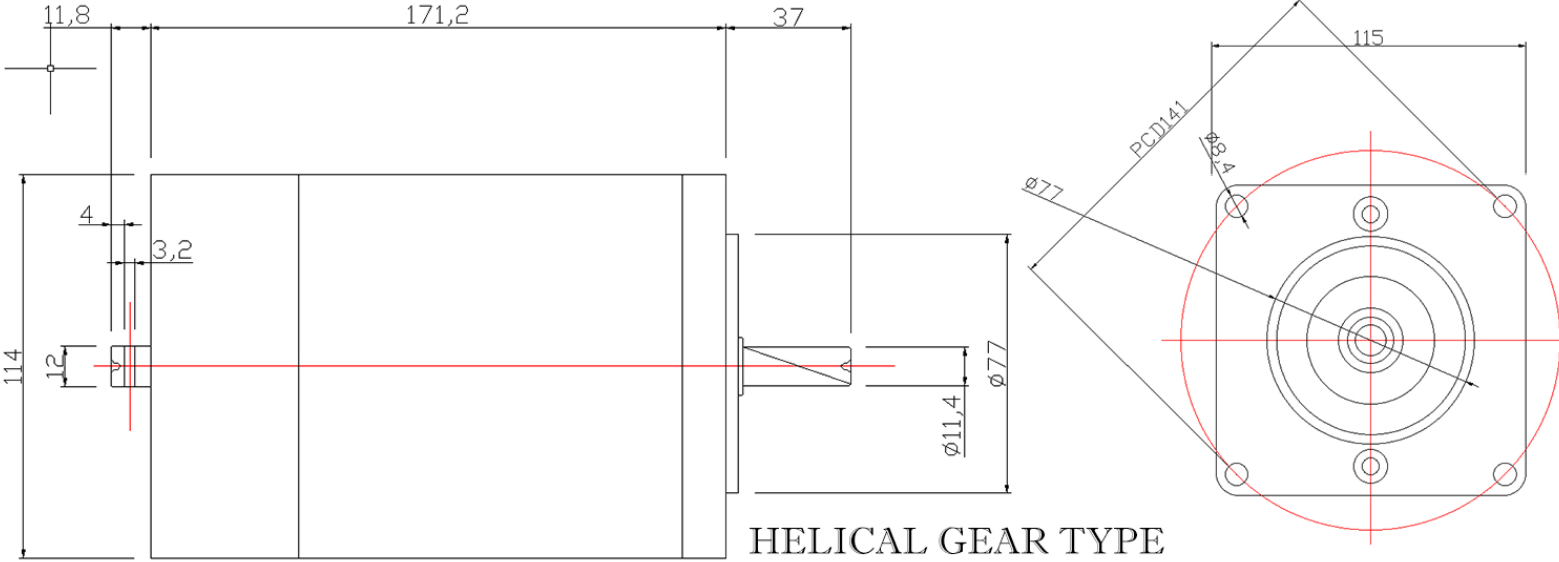

SHAFT 출력축 사양

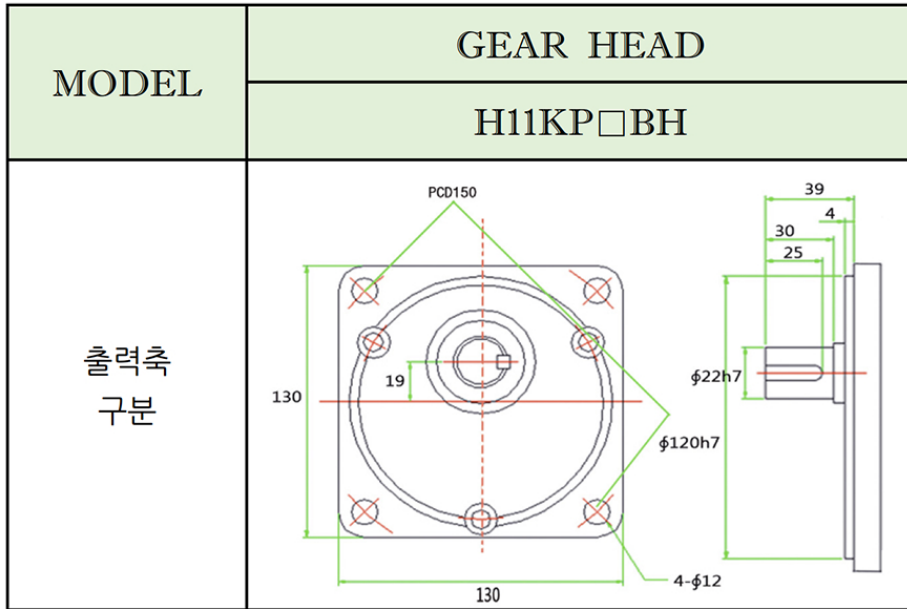

MOTOR SPECIFICATION

MODEL	VOLTAGE (V)	OUTPUT (W)	CURRENT (A)	SPEED (RPM)	TORQUE (kgf-cm)	감속비	OUTPUT (rpm)	LENGTH L(mm)
4H11D750-12□	12	750	88	3000/1800	24.4	1/3~1/60	1200~60	172
4H11D750-24□	24	750	44	3800	24.4	1/3~1/60	1200~60	172
4H11D750-36□	36	750	29.5	3800	24.4	1/3~1/60	1200~60	172
4H11D750-48□	48	750	22	3800	24.4	1/3~1/60	1200~60	172

*업그레이드를 위해 사양이 변경될 수 있습니다.